



**ARIET**

**HD33200H**

## Three-phase online UPS

Online double conversion

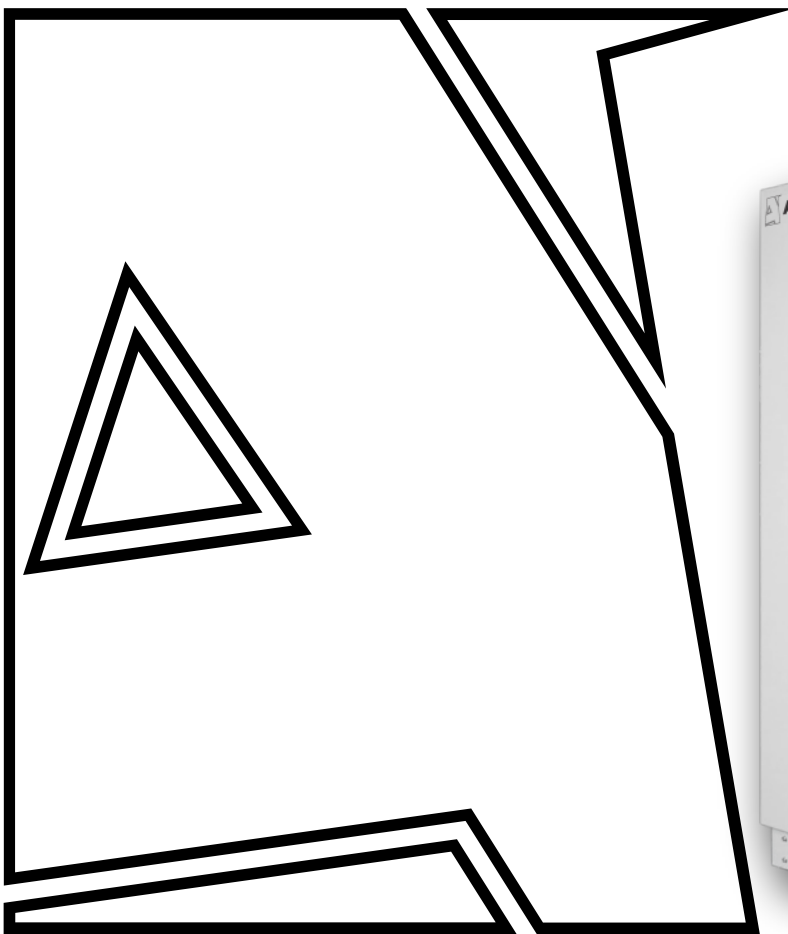

**Critically important  
objects**



**Construction  
organizations**



**Telecommunications  
systems**



**Industrial  
enterprises**

**A three-phase input/three-phase output (3:3) online UPS**, that utilizes a robust phase-controlled thyristor rectifier and IGBT inverter circuit to ensure high reliability and stability, while a built-in isolation transformer further enhances system safety and stability.

A fully digital online system with dual-processor DSP control, three-phase input and output, isolation transformer and zero transfer time, ensuring stable operation with the grid, batteries and diesel generators.



## SCENARIOS

Designed for stable and reliable operation in high temperature conditions without loss of performance characteristics.

The design and materials used ensure resistance to aggressive environmental conditions, including dust, moisture and chemically active substances.

The optimal choice for mission-critical facilities that require increased reliability and resistance to extreme conditions.

## BENEFITS

<p><b>The all-digital architecture</b> based on a dual-processor DSP chip provides advanced control, precise drift-free logic, and ease of upgrade, debugging, and maintenance.</p>	<p><b>The highly reliable topology</b> with a phase-controlled thyristor rectifier, IGBT inverter and isolation transformer improves the safety, shock resistance and electrical isolation of the system.</p>
<p><b>Direct battery-to-bus connection</b> ensures zero-transition time between grid and battery modes, while a static switch provides instant (0 ms) switching between inverter and bypass.</p>	<p><b>The input and output characteristics</b> allow operation with various voltage and frequency standards (380/400/415V, 50/60Hz), providing high output power factor and excellent overload capacity.</p>
<p><b>The POWER WALK IN function</b> ensures smooth operation with diesel generators, prevents starting problems and optimizes power distribution between the generator and battery.</p>	<p><b>The intelligent battery management system</b> automatically switches charging modes, predicts discharge time, and performs self-diagnostics to extend battery life.</p>
<p><b>Support for N+X parallel operation</b> with automatic redundancy allows for the combination of up to six UPS units and ensures high system fault tolerance in the event of main power grid outages.</p>	<p><b>Advanced monitoring and protection features</b>, including RS232/RS485 interfaces, LCD display and a full range of electrical protections, ensure status monitoring, event logging and safe operation of the UPS.</p>

## UPS switch

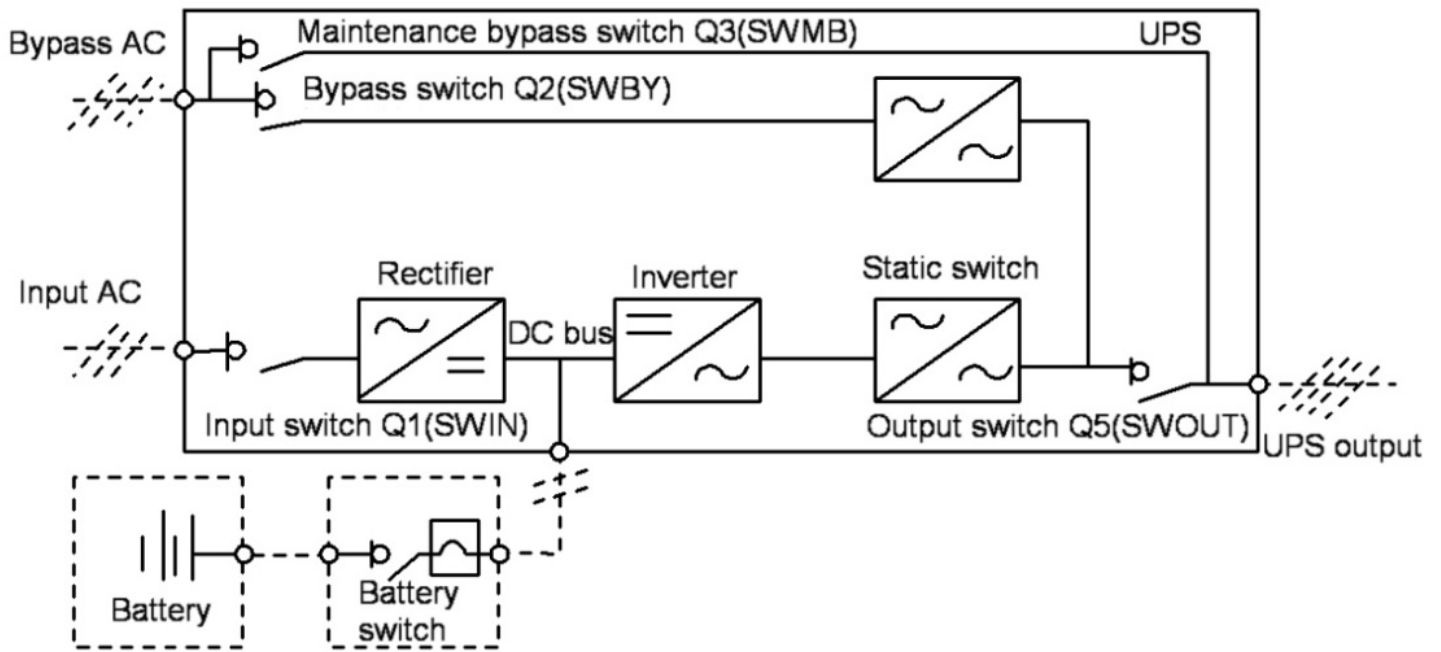

## Installation diagram

160 kVA/200 kVA UPS diagram

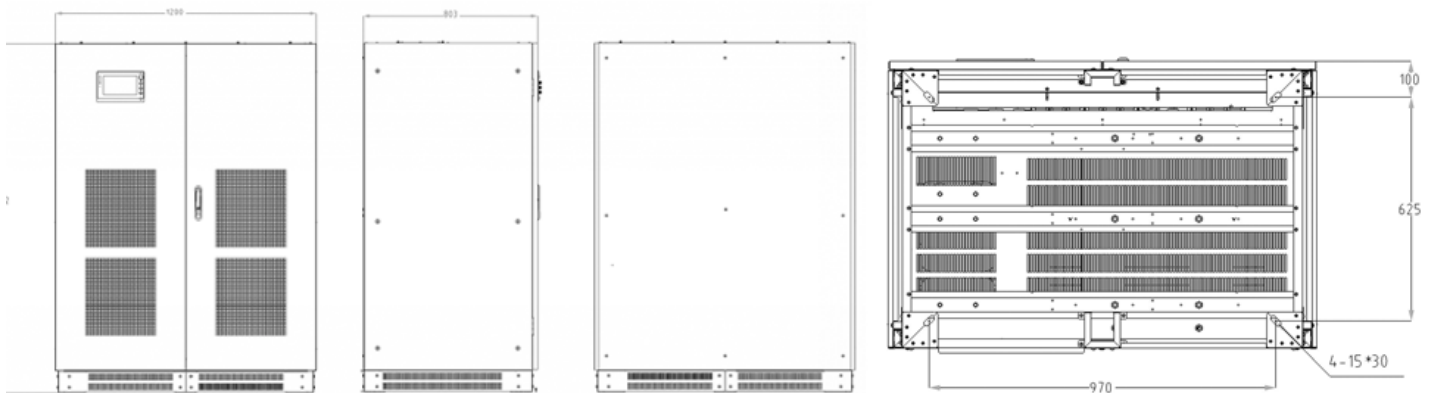

Front view

Side view

Rear view

Bottom view

# Technical specifications

MODEL	HD33200H
Nominal power	200 kVA
<b>Main Input</b>	
Phase	3 phases, 4 wires + ground
Nominal voltage	380/400/415VAC ± 25%
Frequency	45~55Hz / 55~65Hz
Power factor	≥0,97
<b>Bypass</b>	
Phase	3 phases, 4 wires + ground
Frequency	50/60Hz
Frequency range	±2 (±0,5, ±1,±2, ±3 optional)
<b>Output</b>	
Nominal voltage	380/400/415VAC ±1%
Frequency	Automatic tracking of input frequency
Signal form	Pure sine wave
Power factor	0,9
THD	≤1% (100% linear load)
Overload	Load ≤110%, 60 min; Load ≤125%, 10 min; Load ≤150%, 1 min
Crest factor	3:1
Efficiency	≥95%
Battery voltage	360~408VAC
Display	Input and output voltage, frequency, power, battery voltage, current, battery status, load percentage, UPS status, event log
Communication	RS232, RS485, dry contact, SNMP (optional)
<b>Environment</b>	
Operation Temperature	0 ~ 40 °C
Storage temperature	-25 ~ 55 °C (without battery)
Altitude	< 1000 m without power reduction
Humidity	0 ~ 95% (non-condensing)
Noise	< 72 dB
<b>Physical parameters</b>	
Dimensions (W*D*H) mm	800*1200*1600
Net weight (kg)	1030
Standards	EN62040-1, EN62040-2, EN62040-3